

Air Operated Double Diaphragm Pumps

PRODUCT CATALOG

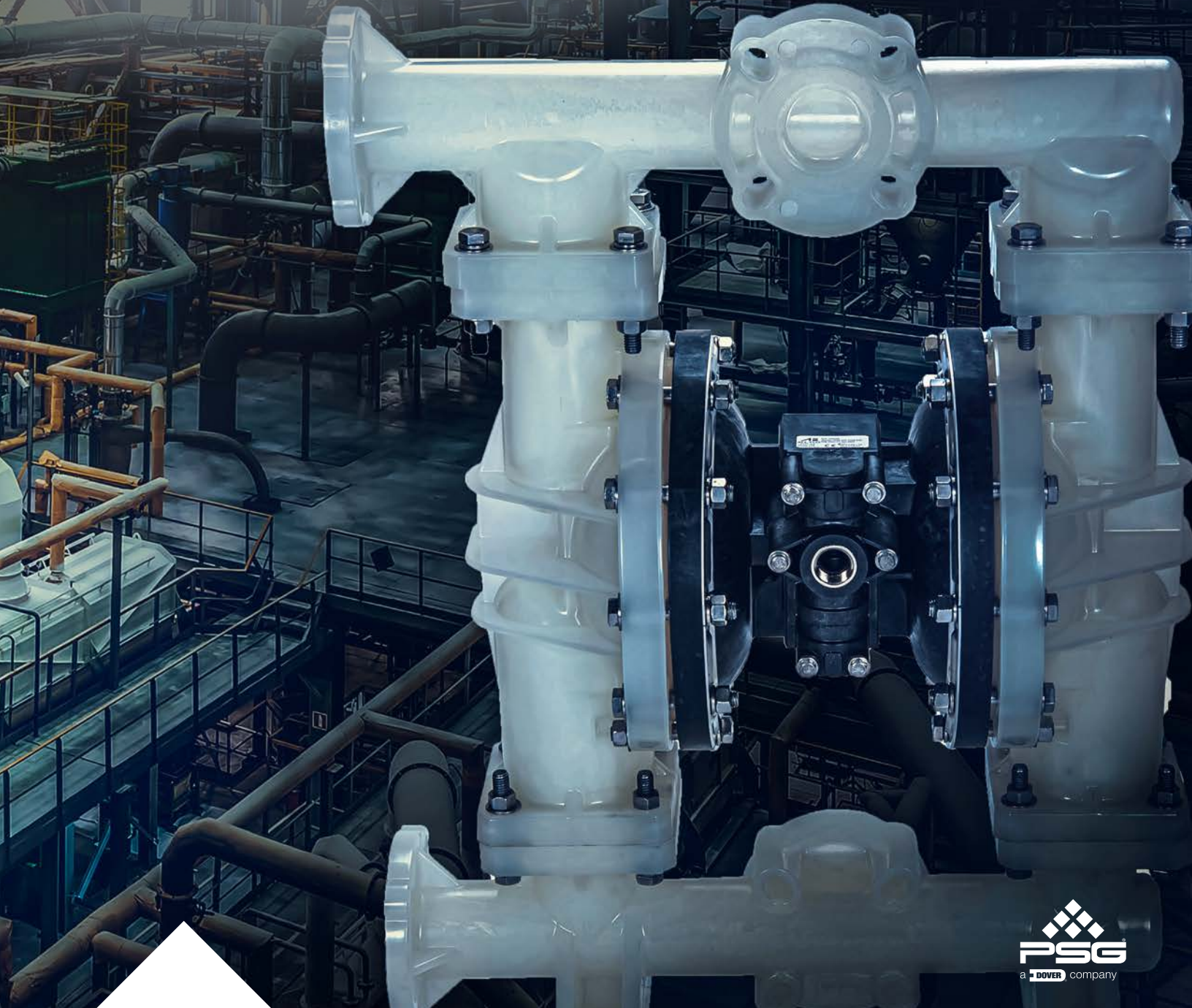

Where Innovation Flows



Performance and Efficiency

Since 1986, All-Flo pumps have been built to last. Designed to live up to their name, All-Flo pumps are performance engineered and quality built to provide trouble-free service under the toughest conditions. All of our pumps are 100% factory tested for quality assurance. Our pump's air mechanism features the fewest moving parts of any pump on the market. With fewer parts to wear and breakdown, the result is reduced risk of disruptions in service and reliable operation. When it comes to simplicity of design, see for yourself how our pump stacks up against competitors.

WE PUMP SOLUTIONS™

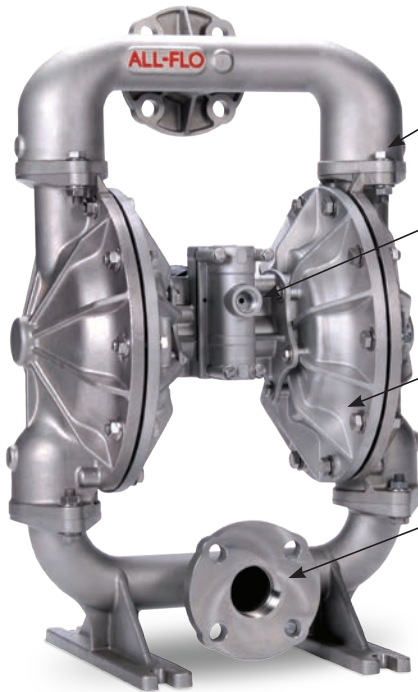

SIMPLE

A simple bolted design ensures quick and easy repairs.

EFFICIENCY

A high efficiency air-valve, with a maximum air pressure of 120 psi (8.2 bar), dramatically reduces overall operating costs.

PERFORMANCE

Quality-built construction of All-Flo pumps delivers unmatched efficiency and performance.

COMPATIBILITY

Mounting feet and liquid porting location designed to match competitors' footprint, reducing replacement cost.



Designed to Reduce Energy Costs

Designed to ensure significant energy savings for customers, All-Flo pumps raise the bar on efficiency standards across the industry. The newly-designed All-Flo pumps boast a high-efficiency air valve, making them the most energy efficient and cost-effective pumps in the industry.



SIMPLE DESIGN

All-Flo's simple air valve design allows for maximum efficiency



OPERATING COSTS

All-Flo pumps yield energy savings of 35-67% over competing pumps



SIMPLE REPAIR

Simple leak free bolted design promotes swift and seamless repairs



CONNECTION & FOOTPRINT

Rest easy — multiple connection types & footprint to match competitors' models

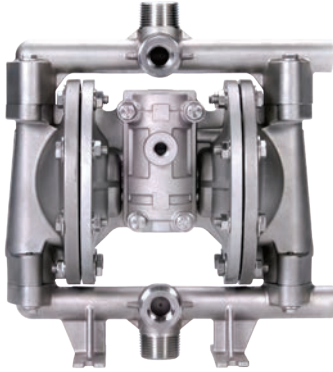

1/2 in. METAL - A050 PUMP

MATERIALS OF CONSTRUCTION

LIQUID SECTION: ALUMINUM, ANODIZED ALUMINUM AND STAINLESS STEEL

AIR SECTION: ALUMINUM AND POLYPROPYLENE (GLASS-FILLED)

ELASTOMERS: GEOLAST®, SANTOPRENE®, FKM AND PTFE

PERFORMANCE SPECIFICATIONS

Max. Flow: 15 gpm (56.8 lpm)

Max. Air Pressure: 120 psi (8.2 bar)

Max. Solids: 1/8" (3.2 mm)

Max. Suction Lift Dry: 15 ft-H₂O (4.5 m-H₂O)

Max. Suction Lift Dry w/ PTFE: 10 ft-H₂O (3.05 m-H₂O)

Max. Suction Lift Wet: 31 ft-H₂O (9.4 m-H₂O)

Weight Aluminum: 10 lbs (4.5 kg)

Weight Stainless Steel: 20 lbs (9.1 kg)

Air Inlet: 1/4" FNPT

Liquid Inlet: 1/2" FNPT or FBSPT

Liquid Outlet: 1/2" FNPT or FBSPT

Height: 11.2" (284 mm)

Width: 10.3" (262 mm)

Depth: 6.4" (163 mm)*

*Polypropylene air section (intermediate) has depth of 7.3" (185mm).

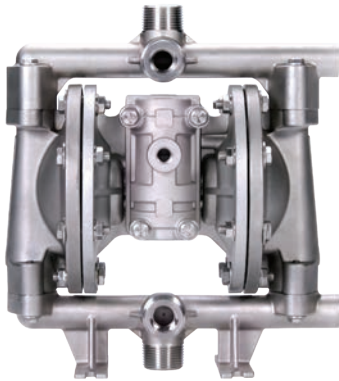
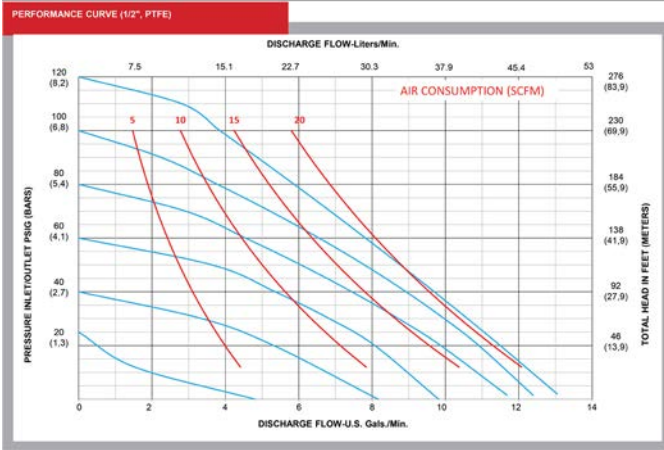

3/4 in. METAL - A075 PUMP

MATERIALS OF CONSTRUCTION

LIQUID SECTION: ALUMINUM, ANODIZED ALUMINUM AND STAINLESS STEEL

AIR SECTION: ALUMINUM AND POLYPROPYLENE (GLASS-FILLED)

ELASTOMERS: GEOLAST®, SANTOPRENE®, FKM AND PTFE

PERFORMANCE SPECIFICATIONS

Max. Flow: 15 gpm (56.8 lpm)

Max. Air Pressure: 120 psi (8.2 bar)

Max. Solids: 1/8" (3.2 mm)

Max. Suction Lift Dry: 15 ft-H₂O (4.5 m-H₂O)

Max. Suction Lift Dry w/ PTFE: 14 ft-H₂O (4.3 m-H₂O)

Max. Suction Lift Wet: 31 ft-H₂O (9.4 m-H₂O)

Weight Aluminum: 10 lbs (4.5 kg)

Weight Stainless Steel: 20 lbs (9.1 kg)

Air Inlet: 1/4" FNPT

Liquid Inlet: 3/4" FNPT or FBSPT (Center Port Only)

Liquid Outlet: 3/4" FNPT or FBSPT (Center Port Only)

Height: 11.2" (284 mm)

Width: 10.3" (262 mm)

Depth: 6.4" (163 mm)*

*Polypropylene air section (intermediate) has depth of 7.3" (185mm).

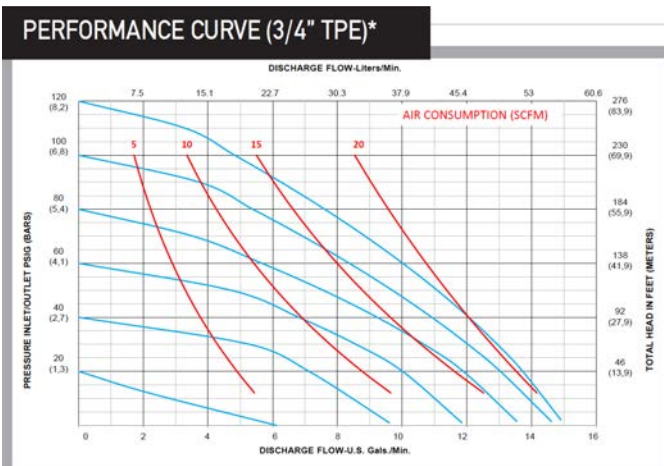



1 in. METAL - A100 PUMP

MATERIALS OF CONSTRUCTION

LIQUID SECTION: ALUMINUM, ANODIZED ALUMINUM AND STAINLESS STEEL

AIR SECTION: ALUMINUM, PTFE COATED ALUMINUM

ELASTOMERS: GEOLAST®, SANTOPRENE®, FKM, PTFE, BUNA-N AND EPDM

PERFORMANCE SPECIFICATIONS

Max. Flow: 48 gpm (182 lpm)

Max. Air Pressure: 120 psi (8.2 bar)

Max. Solids: 1/4" (6.4 mm)

Max. Suction Lift Dry: 17 ft-H₂O (5.2 m-H₂O)

Max. Suction Lift Dry w/ PTFE: 17 ft-H₂O (5.2 m-H₂O)

Max. Suction Lift Wet: 30 ft-H₂O (9.1 m-H₂O)

Weight Aluminum: 18 lbs (8 kg)

Weight Stainless Steel: 38 lbs (17 kg)

Air Inlet: 1/4" FNPT

Liquid Inlet: 1" FNPT or FBSPT

Liquid Outlet: 1" FNPT or FBSPT

Height: 12.4" (315 mm)

Width: 13.0" (330 mm)

Depth: 8.4" (213 mm)*

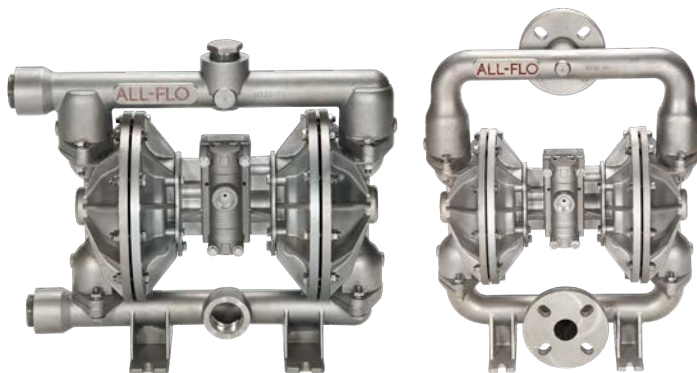
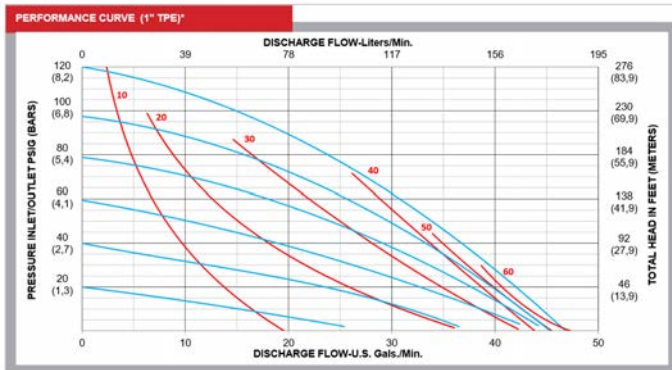

1-1/2 in. METAL - A150 PUMP

MATERIALS OF CONSTRUCTION

LIQUID SECTION: ALUMINUM, ANODIZED ALUMINUM, AND STAINLESS STEEL

AIR SECTION: ALUMINUM AND STAINLESS STEEL

ELASTOMERS: GEOLAST®, SANTOPRENE®, FKM, PTFE, BUNA-N AND EPDM

PERFORMANCE SPECIFICATIONS (1-1/2" PORTS)

Max. Flow: 115 gpm (435 lpm)

Max. Air Pressure: 120 psi (8.2 bar)

Max. Solids: 1/4" (6.4 mm)

Max. Suction Lift Dry: 22 ft-H₂O (6.7 m-H₂O)

Max. Suction Lift Dry w/ PTFE: 18 ft-H₂O (5.5 m-H₂O)

Max. Suction Lift Wet: 31 ft-H₂O (9.4 m-H₂O)

Weight Aluminum: 45 lbs (20 kg)

Weight Stainless Steel: 70 lbs (32 kg) Threaded

Weight Stainless Steel: 84 lbs (38 kg) Flange

Air Inlet: 3/4" FNPT

Liquid Inlet: Aluminum: 1-1/2" FNPT, FBSPT

Stainless Steel: 1-1/2" FNPT, FBSPT, or ANSI/DIN Flange

Liquid Outlet: Aluminum: 1-1/2" FNPT, FBSPT or 1-1/4" FNPT, FBSP (Top Port)

Stainless Steel: 1-1/2" FNPT, FBSPT, or ANSI/DIN Flange

Height: 17.3" (439 mm) Threaded / 23.9" (607 mm) Flange

Width: 20.8" (528 mm) Threaded / 18.8" (478 mm) Flange

Depth: 11.2" (284 mm) Threaded and Flange

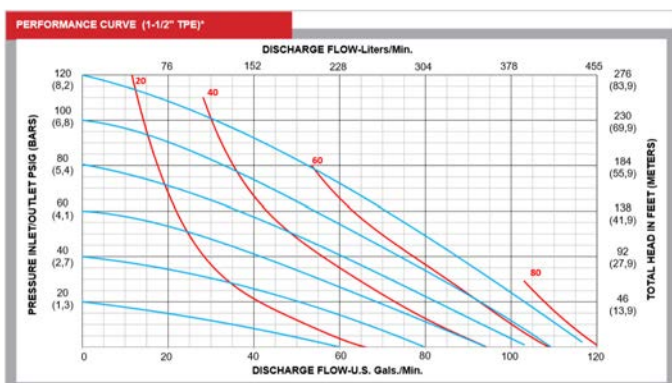

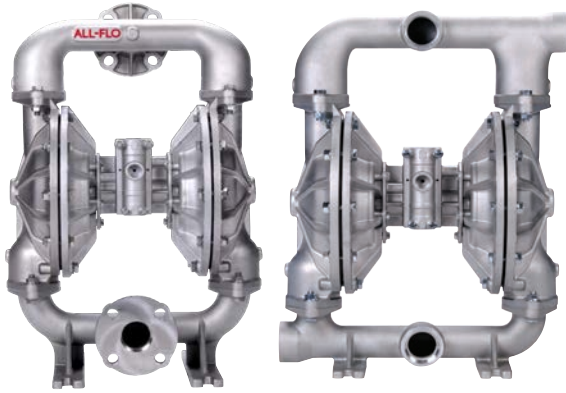

2 in. METAL - A200 PUMP

MATERIALS OF CONSTRUCTION

LIQUID SECTION: ALUMINUM, ANODIZED ALUMINUM AND STAINLESS STEEL

AIR SECTION: ALUMINUM AND STAINLESS STEEL

ELASTOMERS: GEOLAST®, SANTOPRENE®, FKM, PTFE, BUNA-N AND EPDM

PERFORMANCE SPECIFICATIONS

Max. Flow: 190 gpm (719 lpm)

Max. Air Pressure: 120 psi (8.2 bar)

Max. Solids: 1/4" (6.4 mm)

Max. Suction Lift Dry: 24.4 ft-H₂O (7.4 m-H₂O)

Max. Suction Lift Dry w/ PTFE: 19.3 ft-H₂O (5.9 m-H₂O)

Max. Suction Lift Wet: 31.7 ft-H₂O (9.7 m-H₂O)

Weight Aluminum: 62 lbs (28 kg)

Weight Stainless Steel: 130 lbs (59 kg)

Air Inlet: 3/4" FNPT

Liquid Inlet: Aluminum 2" FNPT or FBSP

Stainless Steel 2" FNPT, FBSP or ANSI/DIN Flange

Liquid Outlet: Aluminum 2" FNPT or FBSP

Stainless Steel 2" FNPT, FBSP or ANSI/DIN Flange

Height: 26.3" (668 mm) AL / 29.5" (749 mm) SS

Width: 19.6" (498 mm) AL / 19.2" (488 mm) SS

Depth: 13.5" (343 mm) AL / 14.9" (378 mm) SS

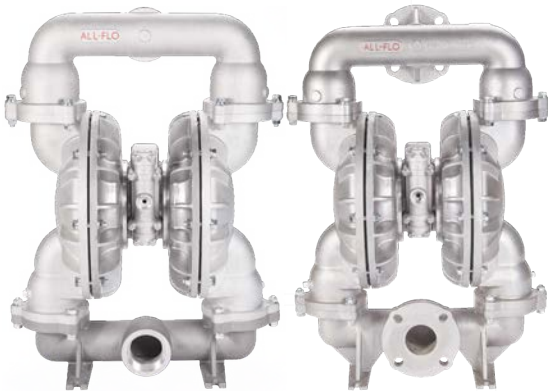
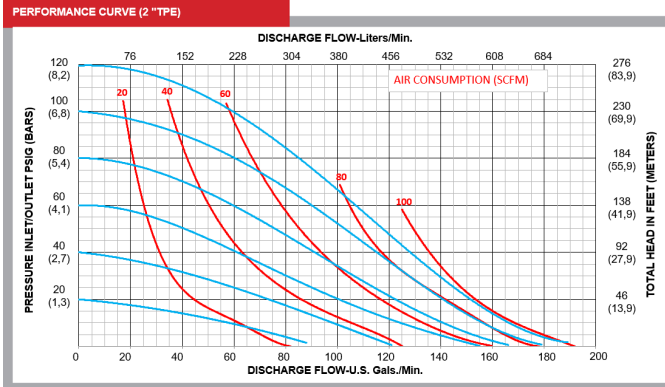

3 in. METAL - A300 PUMP

MATERIALS OF CONSTRUCTION

LIQUID SECTION: ALUMINUM, ANODIZED ALUMINUM AND STAINLESS STEEL

AIR SECTION: ALUMINUM

ELASTOMERS: GEOLAST®, SANTOPRENE®, FKM AND PTFE

PERFORMANCE SPECIFICATIONS

Max. Flow: 235 gpm (890 lpm)

Max. Air Pressure: 120 psi (8.2 bar)

Max. Solids: 7/16" (11.1 mm)

Max. Suction Lift Dry: 20 ft-H₂O (6.1 m-H₂O)

Max. Suction Lift Dry w/ PTFE: 17 ft-H₂O (5.2 m-H₂O)

Max. Suction Lift Wet: 31 ft-H₂O (9.4 m-H₂O)

Weight Aluminum: 135 lbs (62 kg)

Weight Stainless Steel: 300 lbs (136 kg)

Air Inlet: 3" FNPT

Liquid Inlet: 3" FNPT or FBSP

Liquid Outlet: 3" FNPT or FBSP

Height: 32.6" (827 mm) AL / 35.2" (893 mm) SS

Width: 24.8" (633 mm)

Depth: 16.8" (425 mm)*

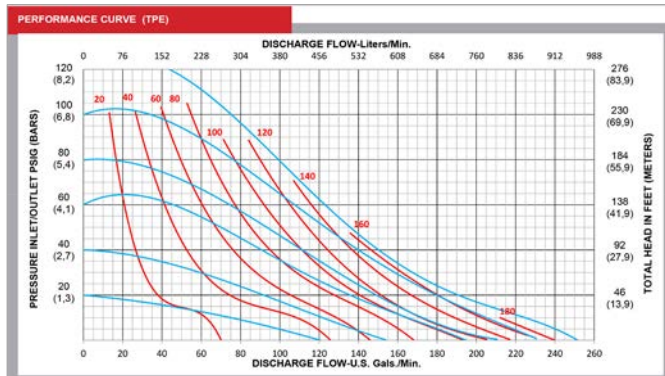



1/4 in. PLASTIC - A025 PUMP

MATERIALS OF CONSTRUCTION

LIQUID SECTION: POLYPROPYLENE, PVDF

AIR SECTION: POLYPROPYLENE

ELASTOMERS: GEOLAST®, SANTOPRENE® AND PTFE

PERFORMANCE SPECIFICATIONS

Max. Flow: 5.7 gpm (21.6 lpm)

Max. Air Pressure: 120 psi (8.2 bar)

Max. Solids: 1/16" (1.6 mm)

Max. Suction Lift Dry: 15 ft-H₂O (4.6 m-H₂O)

Max. Suction Lift Dry w/ PTFE: 10 ft-H₂O (3.0 m-H₂O)

Max. Suction Lift Wet: 28 ft-H₂O (8.5 m-H₂O)

Weight Polypropylene: 2.6 lbs (1.2 kg)

Weight PVDF: 38 lbs (17 kg)

Air Inlet: 1/4" FNPT

Liquid Inlet: 1/4" Internal (NPT/BSP), 3/4" External (NPT)

Liquid Outlet: 1/4" Internal (NPT/BSP), 3/4" External (NPT)

Height: 6.8" (173 mm)

Width: 7.3" (186 mm)

Depth: 4.6" (118 mm)

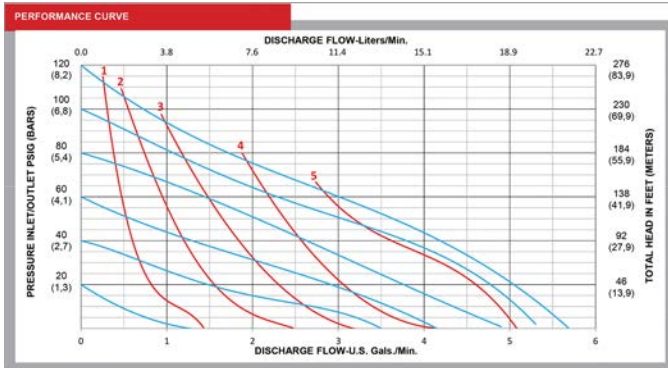

3/8 in. PLASTIC - C038 PUMP

MATERIALS OF CONSTRUCTION

LIQUID SECTION: POLYPROPYLENE, PVDF AND CONDUCTIVE NYLON

AIR SECTION: POLYPROPYLENE

ELASTOMERS: GEOLAST®, SANTOPRENE®, FKM AND PTFE

PERFORMANCE SPECIFICATIONS (1-1/2" PORTS)

Max. Flow: 9 gpm (34 lpm)

Max. Air Pressure: 120 psi (8.2 bar)

Max. Solids: 1/16" (1.6 mm)

Max. Suction Lift Dry: 10 ft-H₂O (3.0 m-H₂O)

Max. Suction Lift Wet: 26 ft-H₂O (7.9 m-H₂O)

Weight Polypropylene and Conductive Nylon: 3.8 lbs (1.7 kg)

Weight PVDF: 5 lbs (2.3 kg)

Air Inlet: 1/4" FNPT

Liquid Inlet: 3/8" FNPT/FBSPT

Liquid Outlet: 3/8" FNPT/FBSPT

Height: 7.2" (183 mm)

Width: 8.6" (217 mm)

Depth: 4.8" (122 mm)

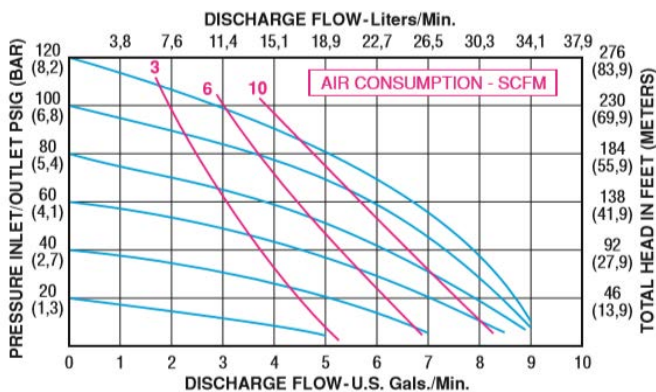

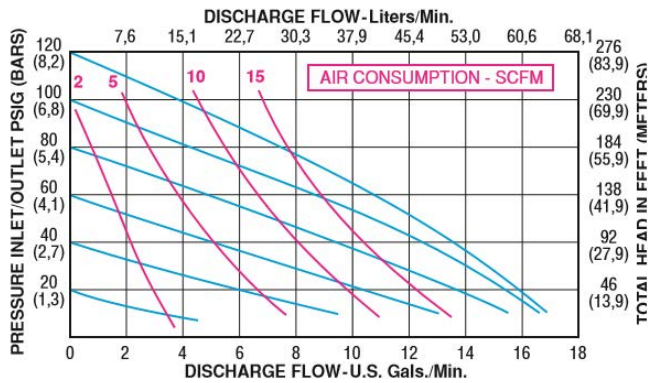

1/2 in. PLASTIC - A050 PUMP

MATERIALS OF CONSTRUCTION

LIQUID SECTION: POLYPROPYLENE, PVDF AND CONDUCTIVE NYLON

AIR SECTION: POLYPROPYLENE

ELASTOMERS: GEOLAST®, SANTOPRENE®, FKM AND PTFE

PERFORMANCE SPECIFICATIONS

Max. Flow: 17 gpm (64.6 lpm)

Max. Air Pressure: 120 psi (8.2 bar)

Max. Solids: 1/8" (3.2 mm)

Max. Suction Lift Dry: 15 ft-H₂O (4.5 m-H₂O)

Max. Suction Lift Dry w/ PTFE: 10 ft-H₂O (3.0 m-H₂O)

Max. Suction Lift Wet: 26 ft-H₂O (7.9 m-H₂O)

Weight Polypropylene: 9 lbs (4.1 kg)

Weight PVDF & Conductive Nylon: 12 lbs (5.4 kg)

Air Inlet: 1/4" FNPT

Liquid Inlet: 1/2" FNPT/FBSPT

Liquid Outlet: 1/2" FNPT/FBSPT

Height: 11.4" (289 mm)

Width: 12.0" (306 mm)

Depth: 7.4" (187 mm)

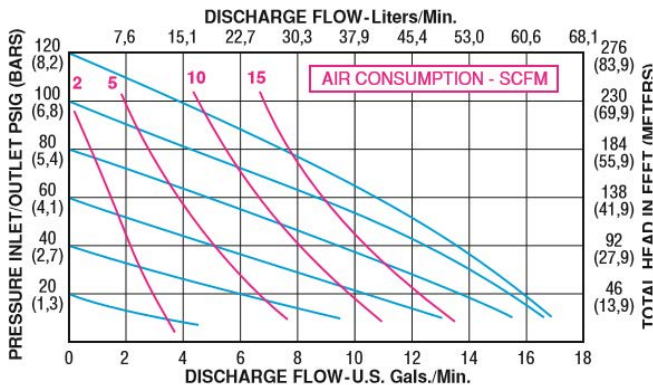

3/4 in. PLASTIC - A075 PUMP

MATERIALS OF CONSTRUCTION

LIQUID SECTION: POLYPROPYLENE, PVDF AND CONDUCTIVE NYLON

AIR SECTION: POLYPROPYLENE

ELASTOMERS: GEOLAST®, SANTOPRENE®, FKM AND PTFE

PERFORMANCE SPECIFICATIONS

Max. Flow: 17 gpm (64.6 lpm)

Max. Air Pressure: 120 psi (8.2 bar)

Max. Solids: 1/8" (3.2 mm)

Max. Suction Lift Dry: 15 ft-H₂O (4.5 m-H₂O)

Max. Suction Lift Dry w/ PTFE: 10 ft-H₂O (3.0 m-H₂O)

Max. Suction Lift Wet: 26 ft-H₂O (7.9 m-H₂O)

Weight Polypropylene: 9 lbs (4.1 kg)

Weight PVDF & Conductive Nylon: 12 lbs (5.4 kg)

Air Inlet: 1/4" FNPT

Liquid Inlet: 3/4" FNPT/FBSPT

Liquid Outlet: 3/4" FNPT/FBSPT

Height: 11.4" (289mm)

Width: 12.0" (306 mm)

Depth: 7.4" (187 mm)





1 in. PLASTIC - A100 PUMP

MATERIALS OF CONSTRUCTION

LIQUID SECTION: POLYPROPYLENE AND PVDF

AIR SECTION: POLYPROPYLENE

ELASTOMERS: GEOLAST®, SANTOPRENE®, FKM AND PTFE

PERFORMANCE SPECIFICATIONS

Max. Flow: 41 gpm (155.8 lpm)

Max. Air Pressure: 120 psi (8.2 bar)

Max. Solids: 1/4" (6.4 mm)

Max. Suction Lift Dry: 15 ft-H₂O (4.5 m-H₂O)

Max. Suction Lift Dry w/ PTFE: 10 ft-H₂O (3.0 m-H₂O)

Max. Suction Lift Wet: 26 ft-H₂O (7.9 m-H₂O)

Weight Polypropylene: 20 lbs (9.1 kg)

Weight PVDF: 30 lbs (13.0 kg)

Air Inlet: 1/4" FNPT

Liquid Inlet: 1" FNPT, FBSPT or ANSI/DIN Flange

Liquid Outlet: 1" FNPT, FBSPT or ANSI/DIN Flange

Height: 16.3" (415 mm)

Width: 17.3" (438 mm)

Depth: 8.9" (226 mm)*

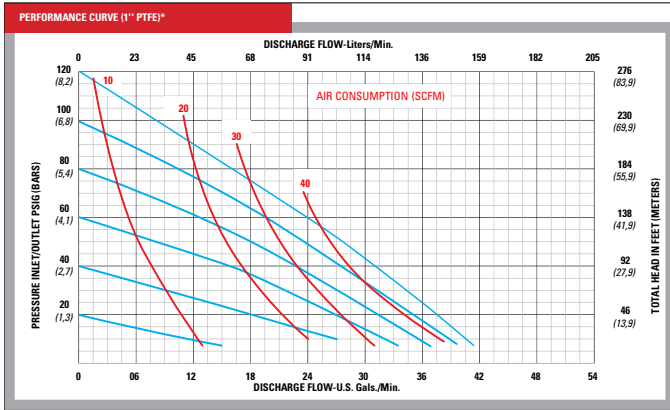

1-1/2 in. PLASTIC - C150 PUMP

MATERIALS OF CONSTRUCTION

LIQUID SECTION: POLYPROPYLENE AND PVDF

AIR SECTION: POLYPROPYLENE

ELASTOMERS: GEOLAST®, SANTOPRENE®, FKM AND PTFE

PERFORMANCE SPECIFICATIONS (1-1/2" PORTS)

Max. Flow: 130 gpm (492 lpm)

Max. Air Pressure: 120 psi (8.2 bar)

Max. Solids: 1/4" (6.4 mm)

Max. Suction Lift Dry: 13 ft-H₂O (3.9 m-H₂O)

Max. Suction Lift Dry w/ PTFE: 10 ft-H₂O (3 m-H₂O)

Max. Suction Lift Wet: 26 ft-H₂O (7.9 m-H₂O)

Weight Polypropylene: 46 lbs (20.8 kg)

Weight PVDF & Conductive Nylon: 65 lbs (29.4 kg)

Air Inlet: 3/4" FNPT

Liquid Inlet: 1-1/2" ANSI/DIN Flange

Liquid Outlet: 1-1/2" ANSI/DIN Flange

Height: 21.8" (553 mm)

Width: 20.6" (523 mm)

Depth: 12.2" (310 mm)

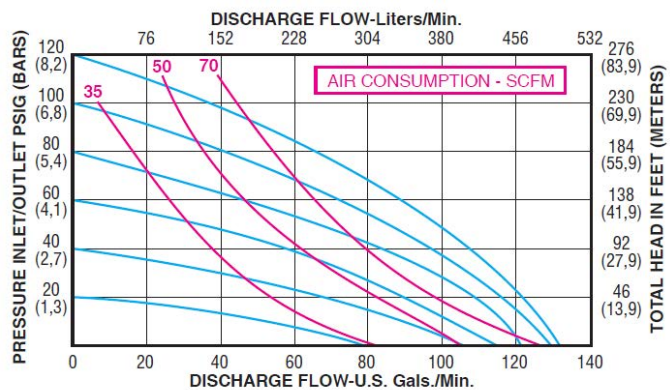

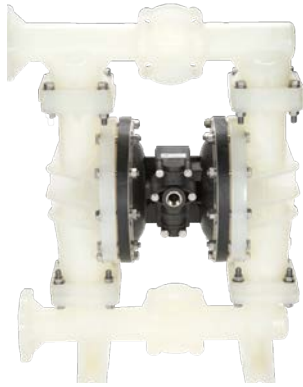

2 in. PLASTIC - A200 PUMP

MATERIALS OF CONSTRUCTION

LIQUID SECTION: POLYPROPYLENE AND PVDF

AIR SECTION: POLYPROPYLENE

ELASTOMERS: GEOLAST®, SANTOPRENE®, FKM AND PTFE

PERFORMANCE SPECIFICATIONS

Max. Flow: 160 gpm (605 lpm)

Max. Air Pressure: 120 psi (8.2 bar)

Max. Solids: 1/4" (6.4 mm)

Max. Suction Lift Dry: 17 ft-H₂O (5.2 m-H₂O)

Max. Suction Lift Dry w/ PTFE: 15 ft-H₂O (4.6m-H₂O)

Max. Suction Lift Wet: 29 ft-H₂O (8.8 m-H₂O)

Weight Polypropylene: 56 lbs (25.0 kg)

Weight PVDF: 84 lbs (38 kg)

Air Inlet: 3/4" FNPT

Liquid Inlet: 2" ANSI/DIN Flange

Liquid Outlet: 2" ANSI/DIN Flange

Height: 31.7" (805 mm)

Width: 23.6" (600 mm)

Depth: 12.2" (310 mm)

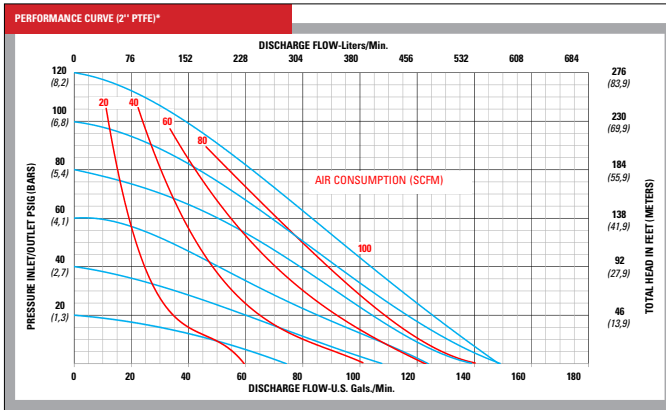

PLASTIC AND CONDUCTIVE PLASTIC D SERIES SPECIALTY PUMPS

MATERIALS OF CONSTRUCTION

LIQUID SECTION: POLYETHYLENE, CONDUCTIVE POLYETHYLENE, PTFE, CONDUCTIVE PTFE

AIR SECTION: POLYETHYLENE, CONDUCTIVE POLYETHYLENE

ELASTOMERS: EPDM, INTEGRAL PTFE

PERFORMANCE SPECIFICATIONS	D038	D050	D100	D150	D200
Fluid Connection Type	FNPT/BSPT	FNPT/BSPT	FNPT/BSPT	FNPT/BSPT	FNPT/BSPT
Fluid Connection Size (in)	3/8"	1/2"	1"	1-1/2"	2"
Air Inlet Connection (in)	1/8" FNPT	1/4" FNPT	1/4" FNPT	1/2" FNPT	1/2" FNPT
Max Lift ft-H ₂ O (m-H ₂ O)	Dry: 3.3 ft-H ₂ O (1 m-H ₂ O) Wet: 29.5 ft-H ₂ O (9 m-H ₂ O)	Dry: 6.6 ft-H ₂ O (2 m-H ₂ O) Wet: 29.5 ft-H ₂ O (9 m-H ₂ O)	Dry: 9.8 ft-H ₂ O (3 m-H ₂ O) Wet: 29.5 ft-H ₂ O (9 m-H ₂ O)	Dry: 13.1 ft-H ₂ O (4 m-H ₂ O) Wet: 29.5 ft-H ₂ O (9 m-H ₂ O)	Dry: 16.4 ft-H ₂ O (5 m-H ₂ O) Wet: 29.5 ft-H ₂ O (9 m-H ₂ O)
Max Solids inches (mm)	1/8" (3 mm)	5/32" (4 mm)	1/4" (6 mm)	7/20" (9 mm)	7/16" (11 mm)
Max Flow Rate gpm (lpm)	6 gpm (22 lpm)	14 gpm (52 lpm)	31 gpm (117 lpm)	80 gpm (300 lpm)	140 gpm (530 lpm)





ALL-PUR™ FDA F SERIES PUMP

MATERIALS OF CONSTRUCTION

LIQUID SECTION: ELECTROPOLISHED AND PASSIVATED 316, STAINLESS STEEL

AIR SECTION: ALUMINUM AND STAINLESS STEEL

ELASTOMERS: FDA HYTREL®, FDA SANTOPRENE® AND FDA PTFE

PERFORMANCE SPECIFICATIONS	F100	F150	F200
Fluid Connection Type	Tri-Clamp®	Tri-Clamp®	Tri-Clamp®
Fluid Connection Size (in)	1-1/2"	2"	2-1/2"
Air Inlet Connection (in)	1/4" FNPT	3/4" FNPT	3/4" FNPT
Max Lift ft-H ₂ O (m-H ₂ O)	Dry: 17 ft-H ₂ O (5.2 m-H ₂ O)	Dry: 22 ft-H ₂ O (6.7 m-H ₂ O)	Dry: 24.4 ft-H ₂ O (7.4 m-H ₂ O)
	Wet: 30 ft-H ₂ O (9.1 m-H ₂ O)	Wet: 31 ft-H ₂ O (9.4 m-H ₂ O)	Wet: 31.7 ft-H ₂ O (9.7 m-H ₂ O)
Max Solids inches (mm)	1/4" (6.4 mm)	1/4" (6.4 mm)	1/4" (6.4 mm)
Max Flow Rate gpm (lpm)	48 gpm (182 lpm)	115 gpm (435 lpm)	190 gpm (719 lpm)



ALL-PUR™ FOOD GRADE G SERIES PUMP

MATERIALS OF CONSTRUCTION

LIQUID SECTION: STAINLESS STEEL

AIR SECTION: CONDUCTIVE POLYETHYLENE

ELASTOMERS: FDA EPDM, INTEGRAL PTFE

PERFORMANCE SPECIFICATIONS	G075	G125	G200
Fluid Connection Type	Tri-Clamp®	Tri-Clamp®	Tri-Clamp®
Fluid Connection Size (in)	1"	1-1/2"	2"
Air Inlet Connection (in)	1/4" FNPT	1/4" FNPT	1/2" FNPT
Max Lift ft-H ₂ O (m-H ₂ O)	Dry: 6.6 ft-H ₂ O (2 m-H ₂ O)	Dry: 6.6 ft-H ₂ O (2 m-H ₂ O)	Dry: 9.8 ft-H ₂ O (3 m-H ₂ O)
	Wet: 29.5 ft-H ₂ O (9 m-H ₂ O)	Wet: 29.5 ft-H ₂ O (9 m-H ₂ O)	Wet: 29.5 ft-H ₂ O (9 m-H ₂ O)
Max Solids in (mm)	7/20" (9 mm)	15/32" (12 mm)	9/16" (14 mm)
Max Flow Rate gpm (lpm)	20 gpm (75 lpm)	40 gpm (150 lpm)	106 gpm (400 lpm)



Pump Accessories and Equipment

PULSATION DAMPENERS



All-Flo PDT Series and PDM Series Plastic and Metal Pulsation Dampeners are recommended accessory products that help expand the application range and augment the performance of All-Flo Air-Operated Double-Diaphragm (AODD) Pumps. Installed at the pump's discharge, All-Flo pulsation dampeners reduce fluid pressure and flow fluctuations to provide a smoother discharge flow. This function is critical in applications that need to minimize system vibration in order to protect and enhance the accuracy of downstream instrumentation. It also extends equipment life by reducing the load on the pump.

SOLENOID VALVES AND BATCH CONTROLLERS



Solenoid control for All-Flo pumps are available in two types: on/off control and integrated pulse control for metering and dispensing applications. On/Off Control are available with air ports in both 3/8" and 3/4" and thus can be used as an accessory on any available pump. Pulse control solenoids are factory installed in 1/4", 3/8", 1/2" and 1" pumps and can be used for dispensing application with our handheld or remote (4-20mA) batch controller. All solenoids are available in 12VDC, 24VDC, 120VAC or 220VAC and utilize a standard DIN 43650B or DIN 43640C connector, depending on the pump size. For batch control, 12VDC solenoids are required. In addition to solenoid control, cycle counters are available on all pumps.



DRUM PUMP KITS

Drum pump kits allow for the convenient transfer of fluids from a 55 gallon drum. Each kit is made of compatible material and comes with a 40 inch tube (for maximum fluid transfer) and a bung adaptor (for connection to the drum). Drum Pump kits are available for all 1/4", 3/8", 1/2" and 1" pumps. For 3/8" pumps and larger, pumps should be configured as bottom suction for use with the drum pump kit.

MISCELLANEOUS PUMP ACCESSORIES



Optional pump accessories include Filter/Regulator Gauges to regulate the air pressure to control the speed of an AODD. Other accessories include grounding kits for use in ATEX applications.



PSG
22069 Van Buren Street
Grand Terrace
CA, 92313-5651
USA
P: +1 (440) 354-1700
F: +1 (440) 354-9466
all-flo.com



Where Innovation Flows

ALF-10010-C-03

Authorized PSG® Partner:

Copyright 2021 PSG®, a Dover company